

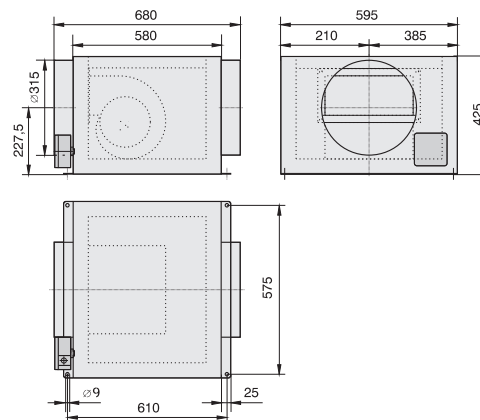

Typ / Type : Z 315 E1		Art.-Nr. / Art.-No. : F05-31507	
U	230V (50Hz)	Δp _{fa} min	– Pa
P ₁	0.55 kW	ΔI	22 %
I _N	2.6 A	I _A / I _N	2.5
n	1360 min ⁻¹		IP54
C _{400V}	12 μF		01.024
t _R	40 °C		40.0 kg



LWA _{rel} A-bewertet bei V=0,5*V _{max} LWA _{rel} A-weighted at V=0,5*V _{max}		fM [Hz]						
		125	250	500	1K	2K	4K	8K
LWA ₂ [dB(A)]	Gehäuse / casing	52	51	43	37	31	26	24
LWA ₅ [dB(A)]	Ansaugseite / inlet side	49	50	44	45	47	44	36
LWA ₆ [dB(A)]	Ausblasseite / outlet side	58	64	67	67	66	64	54